

# Freightliner Circuit - E5

Engine Braking, paddle switch # A06-30769-090  
 Engine/Exhaust Braking, paddle switch # A06-30769-090

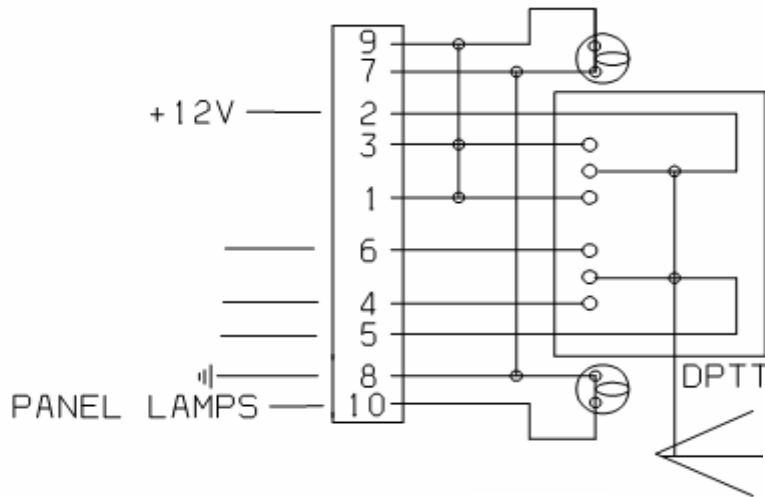

Pin numbers and Connections: **WIRE COLOR** SWITCH POSITIONS >>

>>> **A Crusingator Document** <<<

- |           |  |           |   |
|-----------|--|-----------|---|
| <b>1</b>  | Jumper to Pin 3 & Pin 9                            | <b>6</b>  | 440K, Eng Brake, <b>HI</b> Sig. <b>Red w/White</b>    |
| <b>2B</b> | 81C, Ckt # 1102, <b>Pink</b> , Ignition, 12V+      | <b>7</b>  | Jumper to Pin 8                                       |
| <b>3</b>  | Jumper to Pin 1 & Pin 9                            | <b>8</b>  | Jumper to Pin 7, Ground Ckt # 1204, <b>Black</b>      |
| <b>4</b>  | 440J, Eng Brake, <b>LO</b> Sig. <b>Red w/White</b> | <b>9</b>  | Engine/Exhaust Brake, Switch <b>ON</b> Lamp Power     |
| <b>5B</b> | Ground Ckt # 1204, <b>Black</b>                    | <b>10</b> | 29A, Ckt # 1304, <b>Brown</b> , Dash Panel Lamp, 12V+ |

**HI**  
**OFF**  
**LO**